



QUALITY • PERFORMANCE • RELIABILITY



# CTM-CI-100

4-Post 100 Ton Ceramic Injection Machine\*

\*Shown without CE Guarding for clarity

4717 Hinckley Industrial Parkway, Cleveland, Ohio 44109



**QUALITY • PERFORMANCE • RELIABILITY**



## STANDARD FEATURES

### INJECTION SYSTEM

- + Our in-line injection system allows the material to be injected in a smooth straight line from the injection chamber through our unique nozzle design and into the die. This insures a smooth laminar flow that prevents turbulence.
- + Select from three injection control systems suited to the user's needs. All systems contain excellent temperature, pressure, and flow control.
- + Automatic purge of material after each cycle.
- + Automatic material charge between cycles.
- + 5 zones of temperature control.

### PRESS

- + Available with work table or shuttle table
- + T-Slots on bottom and moving platen
- + Low oil level alarm/shutdown
- + High temperature alarm/shutdown
- + Ultra quiet pumping system
- + Independent platen cooling

### OPERATOR

- + All functions on easy-to-use touch screen interface in user's language
- + Reduced operator fatigue due to ergonomic controls
- + Built to NFPA, ANSI, OSHA, & CE safety standards

### WARRANTY

- + All machines have a full 1 year warranty on all materials and workmanship

*CTM C FRAME WAX INJECTION MACHINES ARE DESIGNED TO PRODUCE THE HIGHEST QUALITY PATTERNS*

# Contact Us Today!

Email: [sales@clevtool.com](mailto:sales@clevtool.com)  
Website: [www.clevtool.com](http://www.clevtool.com)

Tel: (216) 267-6010  
Fax: (216) 267-6011



## 100 Ton Ceramic Injector\*



**ABOVE: CTM CI 100, 100 Ton Ceramic Injector**  
Features: Advanced controls, Shuttle Table, & more  
\*Shown without CE Guarding for clarity

ALL MACHINES ARE AVAILABLE WITH CE SAFETY SYSTEMS FOR EU COUNTRIES

## NOW INCLUDES REMOTE ACCESS!

**ASK ABOUT OUR AVAILABLE OPTIONS TO ENHANCE YOUR MACHINE!**

# CTM-CI-100

## 4-Post 100 Ton Ceramic Injector

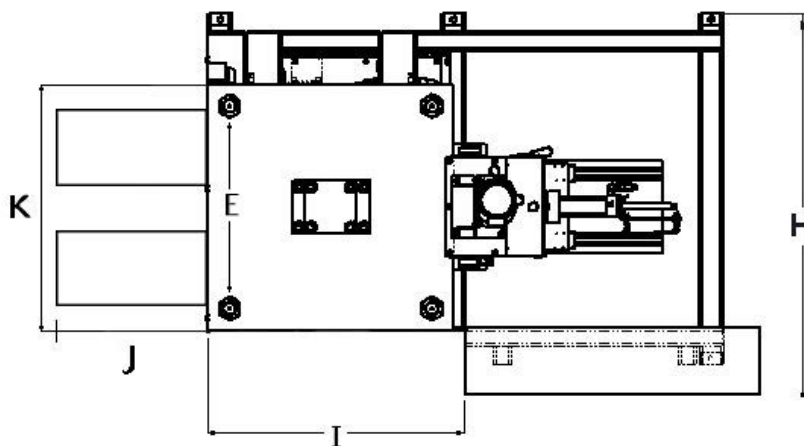
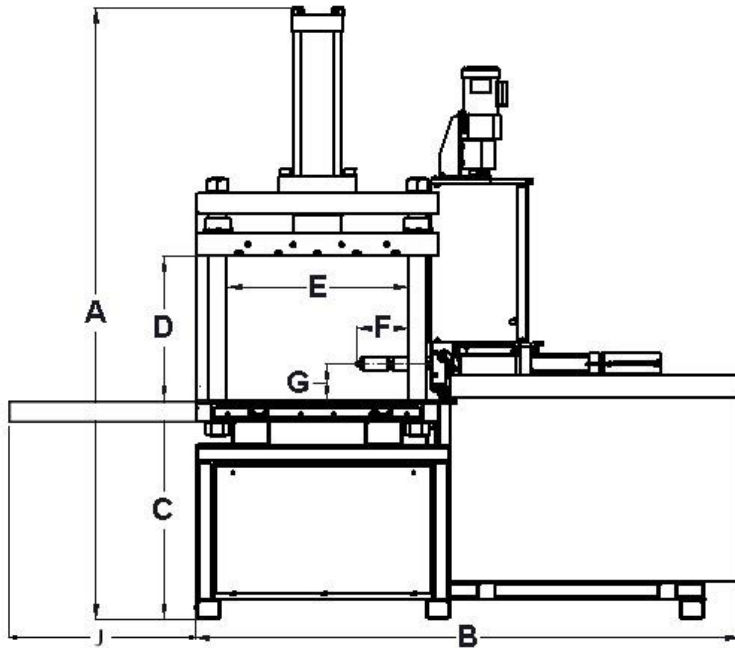

**CTM-CI-100 Ton Specifications**

	Imperial	Metric
Clamp Force- Tons	0-100 Ton	
Press Closing Speed	1.5 in./sec	38 mm/sec
Press Opening Speed	1.5 in./sec	38 mm/sec
Die Mounting	1/2 in T-Slots	
Water Cooled Platens	Included	
Material Holding Tank Capacity	30 Gal	114 Liter
Shot Size	462 cu. In	7.5 Liter
Injection Pressure	0-1000 PSI	69 BAR
Injection Flow Rate Maximum	25 cu.in/sec	425 cc/sec
Injection Cycle Time	0-999 sec	
Nozzle Tip Size	3/8 in. radius	.95 mm radius
Heating System	120 volt- 5+ zones	
Hydraulic System Pressure	2900 PSI	200 BAR
Hydraulic Pump Type	Press. Compensated	
Hydraulic Reservoir Capacity	40 Gal	150 Liter
Hydraulic Cooling System	Water Cooled Heat Exchanger	
Minimum Cooling Water Flow	3 GPM	11 LPM
Maximum Cooling Water Temp	80°F	27 °C
Cooling Water Connection	1/2 inch NPT	
Standard Electric	460V 3Ph 60 HZ 30 @	
Air Pressure (If Required)	60-80 PSI	4.1-5.5 BAR
Approximate Weight	19,000 Lbs	8700 Kgs
A.) Height	117 in	3480 mm
B.) Length	110 in	2790 mm
C.) Floor to Table	36 in	914 mm
D.) Press Opening	4-36 in	100-914 mm
E. Distance between Tie Bars	36 in	914 mm
F.) Nozzle In/Out	0-12 in	0-305 mm
G.) Nozzle Up/Down	2-12 in	50-305 mm
H.) Width	90 in	2286 mm
I.) Press Depth	48 in	1219 mm
J.) Shuttle Table	50 in	1290 mm

\* Special sizes available upon request

\*Pictured Duel Wax Tank Optional



QUALITY • PERFORMANCE • RELIABILITY



## AVAILABLE OPTIONS

- + Electronic Injection Control System
- + Extra Large Color Touch Screen
- + Swing Arm/Pedestal for HMI
- + Data Storage
- + Bar Code Scanner
- + Platen Temperature Control- For heating and cooling
- + PLC Remote Connection
- + Die Transfer Shuttle Table- To move die in and out of press area
- + Increased capacity injection shot sizes
- + Removable Holding Tanks
- + Safety Light Curtains
- + Bottom Injection
- + Pattern Ejection System- Bottom centerline
- + Crane and Hoist
- + Core Pull
- + Remote Injection Nozzle
- + Operator Work Light
- + Water Filtration
- + Temperature Calibration Test Ports
- + Operator Air Gun
- + Magnetic Platens
- + Quick Die Clamping
- + Dual Operator Stations
- + Function/Status Light Towers

## ELECTRONIC INJECTION CONTROLS

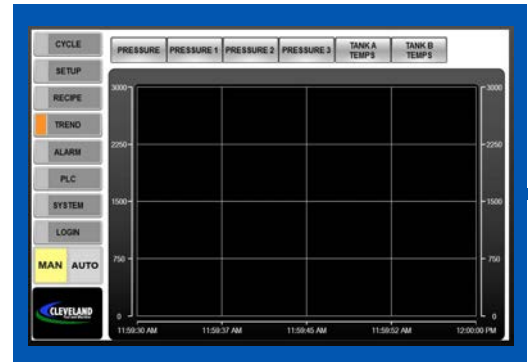
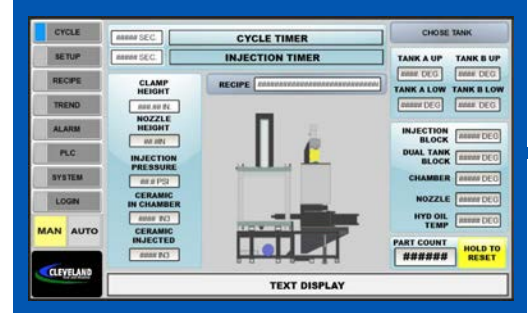

# Contact Us Today!

Email: [sales@clevtool.com](mailto:sales@clevtool.com)  
 Website: [www.clevtool.com](http://www.clevtool.com)

Tel: (216) 267-6010  
 Fax: (216) 267-6011

