



QUALITY • PERFORMANCE • RELIABILITY



CTM-[916]

Automatic Elbow Machine*

*Shown without Power Unit

4717 Hinckley Industrial Parkway, Cleveland, Ohio 44109



QUALITY • PERFORMANCE • RELIABILITY



THE AUTOMATIC ELBOW MACHINE IS DESIGNED TO PRODUCE HIGH QUALITY \varnothing 9", 10", 12", 14", and 16" 90° ELBOWS (+/- 1°)

- Increase productivity
- High quality forming and cutting means less scrap
- Full safety features assures safety of operator and passerby

STANDARD FEATURES

- + Pre-programmed PLC
- + Proportional Valve with amplifier card for accurate cutting height
- + Proportional Valve with Ramping for control of the Gear Head
- + Integrated Lubrication System powered by air
- + Hardened and Heat Treated Tooling
- + Changing Tooling Size takes only 20 minutes!
- + Electrical Supply: 600 VAC 3 \varnothing
- + Safety: Built to NFPA, ANSI, & OSHA safety standards.
Light guards included on all CTM machines
- + 20 second cycles*

OPERATOR

- + All functions on easy-to-use interface

WARRANTY

- + All machines include a full 1 year warranty on all materials and workmanship

RECOMMENDED MATERIAL

- + 0.012"-0.020" Galvanized

*Turning Head option can change to over 20 seconds

Contact Us Today!

Email: sales@clevtool.com
Website: www.clevtool.com

Tel: (216) 267-6010
Fax: (216) 267-6011



916 Automated Elbow Machine

ABOVE: CTM 916 Automated Elbow Machine
Shown with standard light curtains, safety cage, and integrated safety module

ALL MACHINES ARE AVAILABLE WITH CE SAFETY SYSTEMS FOR EU COUNTRIES

NOW INCLUDES REMOTE ACCESS!

ASK ABOUT OUR AVAILABLE OPTIONS TO ENHANCE YOUR MACHINE!



QUALITY • PERFORMANCE • RELIABILITY

CTM-[916]

Automatic Elbow Machines

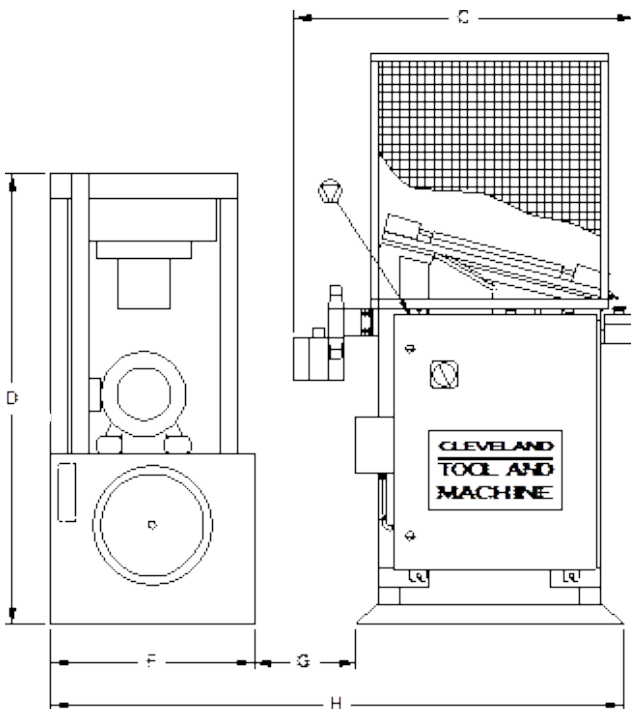
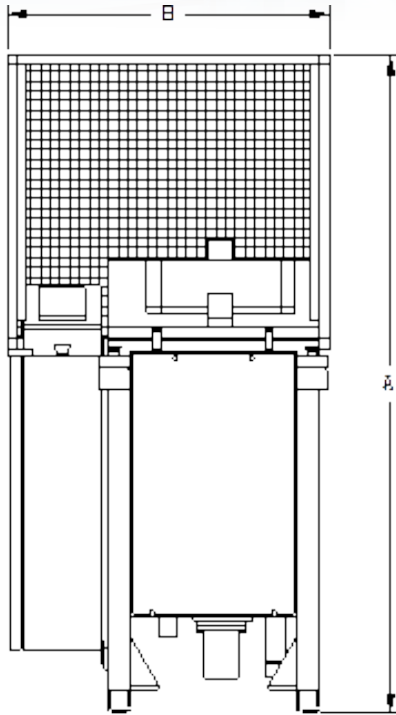

CTM-916 Specifications

	Imperial	Metric
Elbow Machine Height "A"	83 in	2108 mm
Elbow Machine Width "B"	46 in	1168 mm
Elbow Machine Depth "C"	50 in	1270 mm
Hyd. Power Unit Height "D"	55 in	1397 mm
Hyd. Power Unit Width "E"	36 in*	914 mm*
Hyd. Power Unit Depth "F"	24 in	609 mm
Machine to Hyd. Power Unit "G"	12 in	305 mm
Machine + Power Unit "H"	86 in	2184 mm
Approximate Weight	2500 Lbs	1133.9 Kgs
Approximate Cycle Time	20 seconds	
Recommended Material	0.012-0.020" Thick Sheet Metal	
Voltage	200-600 VAC, 3 ϕ , 60 Hz	
Power	10 HP	7.457 KW
Current	32-11 Amps	
Disconnect	40-20 Amps, Circuit Breaker	
Main Power Wire Size	3 Conductors @ #8 AWG 1 Ground @ #10 AWG	
Main Power Connection at Machine	3/4" Sealrite	
Hydraulic Pump Pressure	1100 PSI	75.84 BAR
Hydraulic Pump Flow Rate	15 GPM	56.8 LPM
Hydraulic Reservoir Capacity	40 Gallons	151.4 Liters
Hydraulic Fluid	Hydraulic Oil AW 46	

*Not Shown



QUALITY • PERFORMANCE • RELIABILITY



AVAILABLE OPTIONS

- + Turning Heads
- + Remote Access
- + Unloader
- + Electric Servo Motor Upgrade



916 Automated Elbow Machine

ELECTRONIC ON-SCREEN CONTROLS



**MACHINE SET FOR
9" TUBE
PRESS START**

MAIN MENU 9" TUBE

**F2=SETUP
F3=RUN
F4=SIZE CHANGE
F5=TURNING HEAD ON
F6=TURNING HEAD OFF**

RUN MODE 9" TUBE

**DAILY COUNTER
00000**

**F4 PERMANENT COUNTER
F8 RESET DAILY COUNTER**

**F1 MAIN
MENU**

Contact Us Today!

Email: sales@clevtool.com
 Website: www.clevtool.com

Tel: (216) 267-6010
 Fax: (216) 267-6011

