



QUALITY • PERFORMANCE • RELIABILITY



CTM-[678]

Automatic Elbow Machine*

*Shown without Power Unit

4717 Hinckley Industrial Parkway, Cleveland, Ohio 44109



QUALITY • PERFORMANCE • RELIABILITY



THE AUTOMATIC ELBOW MACHINE IS DESIGNED TO PRODUCE HIGH QUALITY ϕ 6", 7", 8" 90° ELBOWS (+/- 1°)

- Increase productivity
- High quality forming and cutting means less scrap
- Full safety features assures safety of operator and passerby

STANDARD FEATURES

- + Pre-programmed PLC
- + Proportional Valve with amplifier card for accurate cutting height
- + Proportional Valve with Ramping for control of the Gear Head
- + Integrated Lubrication System powered by air
- + Hardened and Heat Treated Tooling
- + Changing Tooling Size takes only 20 minutes!
- + Electrical Supply: 600 VAC 3Ø
- + Safety: Built to NFPA, ANSI, & OSHA safety standards.
Light guards included on all CTM machines
- + Under 18 second cycles!*

OPERATOR

- + All functions on easy-to-use interface

WARRANTY

- + All machines include a full 1 year warranty on all materials and workmanship

RECOMMENDED MATERIAL

- + 0.012"-0.020" Galvanized

*Turning Head option can change to over 20 seconds

Contact Us Today!

Email: sales@clevtool.com
Website: www.clevtool.com

Tel: (216) 267-6010
Fax: (216) 267-6011



678 Automated Elbow Machine

ABOVE: CTM 678 Automated Elbow Machine
Shown with standard light curtains, safety cage, and integrated safety module

ALL MACHINES ARE AVAILABLE WITH CE SAFETY SYSTEMS FOR EU COUNTRIES

NOW INCLUDES REMOTE ACCESS!

ASK ABOUT OUR AVAILABLE OPTIONS TO ENHANCE YOUR MACHINE!



QUALITY • PERFORMANCE • RELIABILITY

CTM-[678]

Automatic Elbow Machines

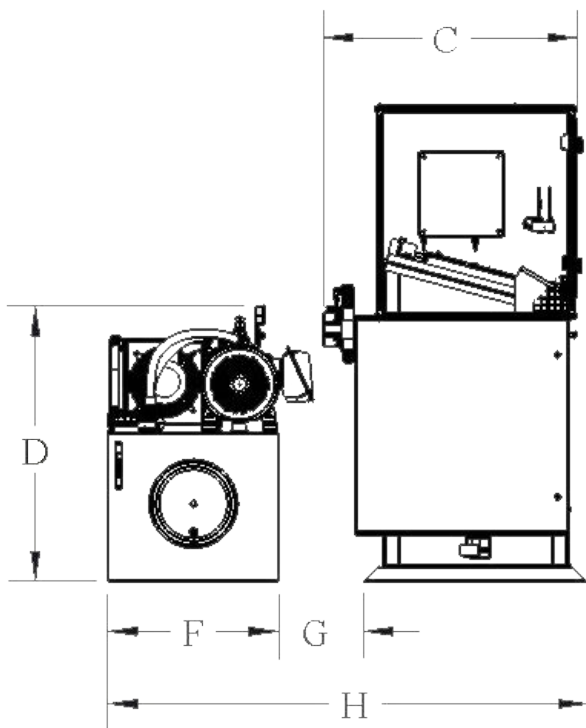
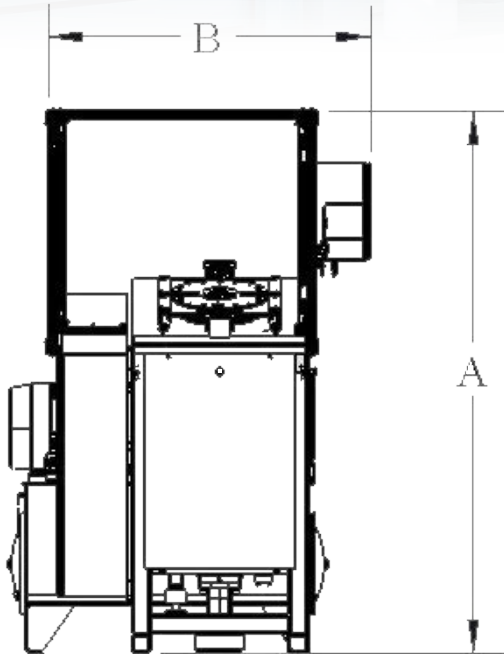

CTM-678 Specifications

	Imperial	Metric
Elbow Machine Height "A"	68 in	1727 mm
Elbow Machine Width "B"	40 in	1016 mm
Elbow Machine Depth "C"	36 in	914 mm
Hydraulic Power Unit Height "D"	39 in	990.6 mm
Hydraulic Power Unit Width "E"	36 in*	914 mm
Hydraulic Power Unit Depth "F"	24 in	609 mm
Machine to Hydraulic Power Unit "G"	12 in	304 mm
Machine + Power Unit "H"	68 in	1727 mm
Approximate Weight	2000 Lbs	907 Kg
Approximate Cycle Time	22 seconds	
Recommended Material	0.012-0.020" thick Sheet Metal	
Voltage	460/230 VAC, 3 ϕ , 60 Hz	
Power	10 HP	7.457 Kw
Current	12.9 Amps	
Disconnect	20 Amps, Circuit Breaker	
Main Power Wire Size	3 Conductors & 1 Ground @ #8 AWG	
Main Power Connection at Machine	3/4" Sealrite	
Hydraulic Pump Pressure	1100 PSI	75.84 BAR
Hydraulic Pump Flow Rate	16 GPM	60.57 LPM
Hydraulic Reservoir Capacity	40 Gallons	151.42 Liters
Hydraulic Fluid	Automatic Transmission Fluid	
*Not Shown		



QUALITY • PERFORMANCE • RELIABILITY



AVAILABLE OPTIONS

- + Turning Heads
- + Unloader
- + Electric Servo Motor Upgrade



678 Automated Elbow Machine

ELECTRONIC ON-SCREEN CONTROLS



**MACHINE SET FOR
7" TUBE
PRESS START**

MAIN MENU

7" TUBE

- F2=SETUP
- F3=RUN
- F4=SIZE CHANGE
- F5=TURNING HEAD ON
- F6=TURNING HEAD OFF

RUN MODE

7" TUBE

**DAILY COUNTER
00000**

- F4 PERMANENT COUNTER
- F8 RESET DAILY COUNTER

F1 MAIN MENU

Contact Us Today!

Email: sales@clevtool.com
Website: www.clevtool.com

Tel: (216) 267-6010
Fax: (216) 267-6011

