



QUALITY • PERFORMANCE • RELIABILITY



# ***CTM-[456]***

## **Automatic Elbow Machine\***

\*Shown without Power Unit

4717 Hinckley Industrial Parkway, Cleveland, Ohio 44109



QUALITY • PERFORMANCE • RELIABILITY



THE AUTOMATIC ELBOW MACHINE IS DESIGNED TO PRODUCE HIGH QUALITY  $\varnothing$  4", 5", 6" 90° ELBOWS (+/-1°)

- Increase productivity
- High quality forming and cutting means less scrap
- Full safety features assures safety of operator and passerby

### STANDARD FEATURES

- + Pre-programmed PLC
- + Proportional Valve with amplifier card for accurate cutting height
- + Proportional Valve with Ramping for control of the Gear Head
- + Integrated Lubrication System powered by air
- + Hardened and Heat Treated Tooling
- + Changing Tooling Size takes only 20 minutes!
- + Electrical Supply: 480/230/600 VAC 3Ø
- + Safety: Built to NFPA, ANSI, & OSHA safety standards.  
Light guards included on all CTM machines
- + Under 18 second cycles!\*

### OPERATOR

- + All functions on easy-to-use interface

### WARRANTY

- + All machines include a full 1 year warranty on all materials and workmanship

### RECOMMENDED MATERIAL

- + 0.012"-0.020" Galvanized

\*Turning Head option can change to over 20 seconds

## Contact Us Today!

Email: sales@clevtool.com  
Website: www.clevtool.com

Tel: (216) 267-6010  
Fax: (216) 267-6011



456 Automated Elbow Machine

ABOVE: CTM 456 Automated Elbow Machine  
Shown with standard light curtains, safety cage, and integrated safety module

ALL MACHINES ARE AVAILABLE WITH CE SAFETY SYSTEMS FOR EU COUNTRIES

NOW INCLUDES REMOTE ACCESS!

ASK ABOUT OUR AVAILABLE OPTIONS TO ENHANCE YOUR MACHINE!



QUALITY • PERFORMANCE • RELIABILITY

# CTM-[456]

## Automatic Elbow Machines

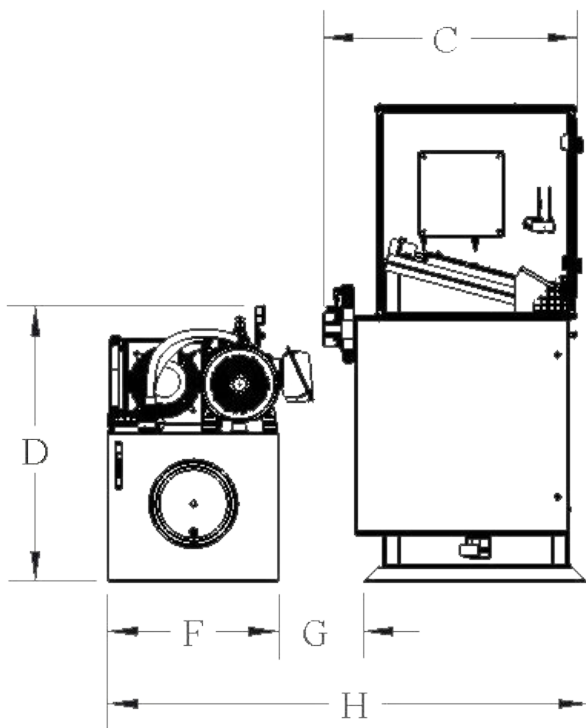
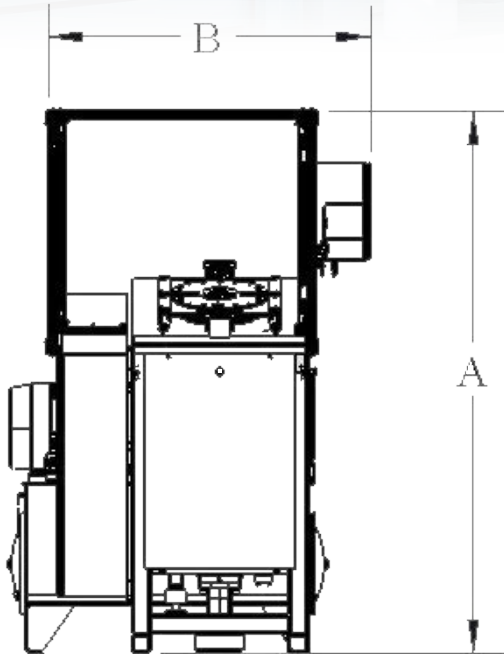

### CTM-456 Specifications

	Imperial	Metric
Elbow Machine Height "A"	68 in	1727 mm
Elbow Machine Width "B"	40 in	1016 mm
Elbow Machine Depth "C"	36 in	914 mm
Hydraulic Power Unit Height "D"	39 in	990.6 mm
Hydraulic Power Unit Width "E"	36 in*	914 mm*
Hydraulic Power Unit Depth "F"	24 in	609 mm
Machine to Hydraulic Power Unit "G"	12 in	304 mm
Machine + Power Unit "H"	68 in	1727 mm
Approximate Weight	2000 Lbs	907 Kg
Approximate Cycle Time	18 seconds	
Recommended Material	0.012-0.020" Thick Sheet Metal	
Voltage	460/230/600 VAC, 3 $\phi$ , 60 Hz	
Power	10 HP	7.457 Kw
Current	12.9 Amps	
Disconnect	20 Amps, Circuit Breaker	
Main Power Wire Size	3 Conductors & 1 Ground @ #8 AWG	
Main Power Connection at Machine	3/4" Sealrite	
Hydraulic Pump Pressure	1100 PSI	75.84 BAR
Hydraulic Pump Flow Rate	16 GPM	60.57 LPM
Hydraulic Reservoir Capacity	40 Gallons	151.42 Liters
Hydraulic Fluid	Automatic Transmission Fluid	
*Not Shown		



QUALITY • PERFORMANCE • RELIABILITY



## AVAILABLE OPTIONS

- + Turning Heads
- + Unloader
- + Electric Servo Motor Upgrade



456 Automated Elbow Machine

## ELECTRONIC ON-SCREEN CONTROLS



**MACHINE SET FOR  
4" TUBE  
PRESS START**

**MAIN MENU**

**4" TUBE**

- F2=SETUP
- F3=RUN
- F4=SIZE CHANGE
- F5=TURNING HEAD ON
- F6=TURNING HEAD OFF

**RUN MODE**

**4" TUBE**

**DAILY COUNTER  
00000**

- F4 PERMANENT COUNTER
- F8 RESET DAILY COUNTER

F1 MAIN  
MENU

# Contact Us Today!

Email: [sales@clevtool.com](mailto:sales@clevtool.com)  
Website: [www.clevtool.com](http://www.clevtool.com)

Tel: (216) 267-6010  
Fax: (216) 267-6011

